

RC-19S1N12Z200 - 1602931

Please be informed that the data shown in this PDF Document is generated from our Online Catalog. Please find the complete data in the user's documentation. Our General Terms of Use for Downloads are valid (<http://phoenixcontact.com/download>)

Cable connector, with Pg11 connection thread, angled, shielded: no, Screw locking, M23, No. of pos.: 16+3, type of contact: Socket, Solder connection

RoHS

Key Commercial Data

Packing unit	8 pc
GTIN	 4 046356 879125
GTIN	4046356879125

Technical data

Environmental Product Compliance

REACH SVHC	Lead 7439-92-1
China RoHS	Environmentally Friendly Use Period = 50
	For details about hazardous substances go to tab "Downloads", Category "Manufacturer's declaration"

Drawings

Schematic diagram

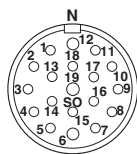

Dimensional drawing

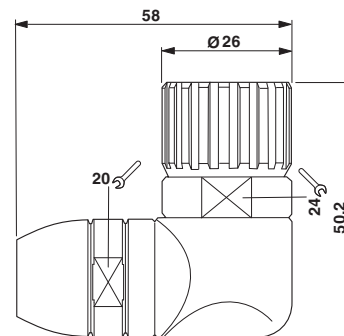

Approvals

Approvals

RC-19S1N12Z200 - 1602931

Approvals

Approvals

EAC

Ex Approvals

Approval details

EAC		B.01742
-----	---	---------

Phoenix Contact 2018 © - all rights reserved
<http://www.phoenixcontact.com>

PHOENIX CONTACT GmbH & Co. KG
Flachsmarktstr. 8
32825 Blomberg
Germany
Tel. +49 5235 300
Fax +49 5235 3 41200
<http://www.phoenixcontact.com>

Mouser Electronics

Authorized Distributor

Click to View Pricing, Inventory, Delivery & Lifecycle Information:

[Phoenix Contact:](#)

[1602931](#)